

# High-speed series TM Xpress 160 – 450 t



*Your fast track to business success*

Technology working for you.

**Battenfeld**  
world of innovation

# Special attributes of the TM Xpress series 160 – 450 t

## The TM Xpress series – your fast track to business success

The HYBRID variant of the powerful high-speed model with clamping forces ranging from 160 to 450 t. Compact power packages of the TM series from WITTMANN BATTENFELD in the high-speed versions. The new, innovative TM Xpress series stands for excellent injection performance and accuracy.

The user-friendly UNILOG B6 control system offers a wide range of functions, providing support in process monitoring and documentation.

Combine speed with cost-efficiency. Let the TM Xpress fascinate you.



### 1 Clamping system

A rigid machine frame combined with reinforced bearing bolts and low-maintenance toggle jacks stands for high-precision, low-maintenance requirements and a long service life. The differential switching system of the clamping cylinder allows high opening and closing speeds and minimal dry cycle times.



### 2 Linear guides

Since the moving platen is supported by high-precision linear guides, no additional adjustment for complex molds is required. Lubrication has been reduced to a minimum. As they have no guiding functions, the hard-chrome-plated tie bars are free of lubricant residues.

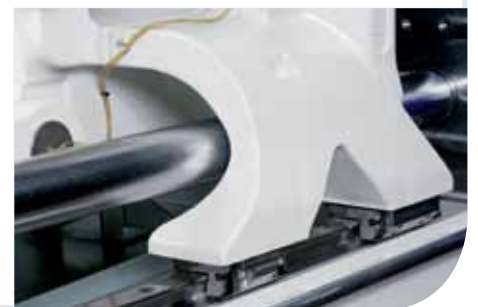



### 3 *Injection unit*

The various barrels and screws come with a uniform L/D ratio of 22 : 1 or 26 : 1. The injection unit is mounted on linear guides. A separate service stroke function is available for insertion and removal of barrels and screws.

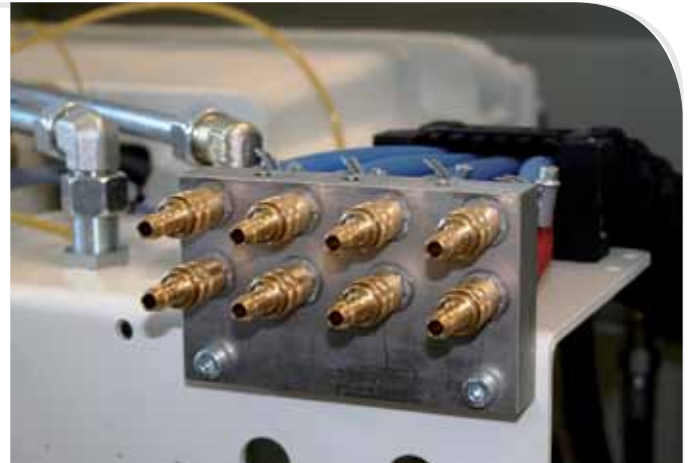

### 4 *Utility connections*

The machine concept provides sufficient space for utility connections at the rear. Cooling water and air supply pipes and cables for electrical signals can be connected to the moving platen according to customers' wishes.

### 5 *Metering motor – servo-electric*

A drive motor placed in the longitudinal axis of the machine takes care of the screw drive. Combined with a barrier compounding screw, this drive operates with high energy efficiency and ensures optimal homogeneity in the material being processed.



### 6 *Hydraulic accumulator*

Hydraulic accumulators to handle the machine's high injection performance are mounted at the rear. Thanks to their short distance to the injection cylinders, a high reaction speed with minimal pressure loss is achieved.



# Clamping unit and injection unit TM Xpress 160 t – 450 t

## Clamping unit

### Outstanding features of the TM Xpress

- Short footprint.
- Extremely rigid, sturdy clamping plates and machine frame.
- Precise platen parallelism across the entire stroke.
- Low-maintenance linear guides to support the moving platen.
- Self-locking 5-point toggle system.
- Reinforced toggle bearings with low-maintenance toggle sleeves.
- Adhesive central oil lubrication of toggle system.
- High opening and closing speeds thanks to differential gears.
- Short dry cycle times.
- Flexible parts removal in three directions.
- High repeatability of all parameter settings.
- Sensitive mold safety device.
- Mold protection thanks to precise platen parallelism, minimal platen deflection and linear guides.
- Low-maintenance and service-friendly design of all machine parts.

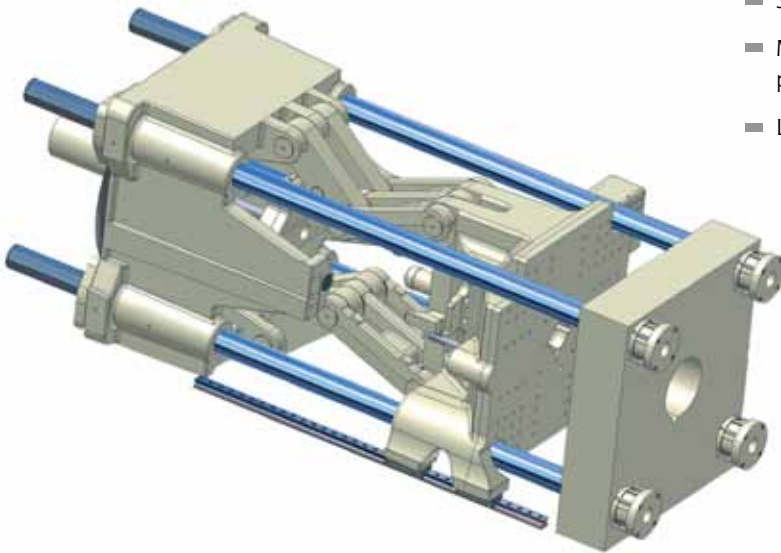

## Injection unit

### A concept to improve parts quality

- Optimal homogeneity thanks to a uniform screw L/D ratio of 22 : 1 or 26 : 1 in combination with barrier compounding screws for processing HDPE, PP and PS.
- Min. 2,000 bar injection pressure for all screw diameters.
- High injection rate combined with acceleration rates of 10,000 mm/sec<sup>2</sup>.
- Precise axial movements of the injection unit thanks to linear guides.
- Torque-free parallel nozzle contact due to positioning of traveling cylinders opposite each other.

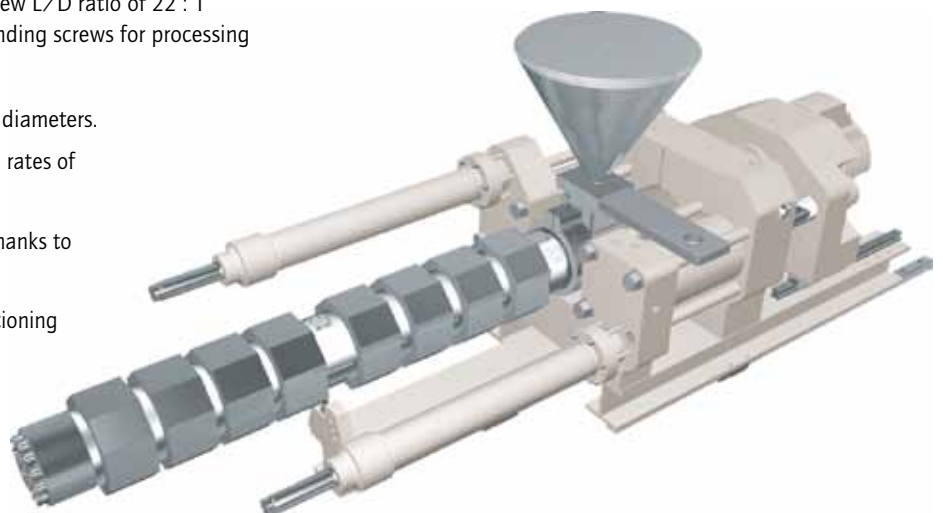

### *Ultimate precision and repeatability*

- Compact design with integrated hydraulic block and easy access to all components.
- Maximum repeatability thanks to servo-valve control.

### *High-performance plasticizing systems*

- High plasticizing performance with barrier screw.
- Melting performance and homogeneity optimized by additional compounding section.
- Long service life thanks to optimal choice of materials.



### *Servo motor for metering*

- The screw drive is powered by a servo motor positioned in the longitudinal axis of the machine.
- With circumferential speeds reaching more than 1 m/s, an extremely high plasticizing performance with simultaneous low energy consumption is achieved.
- Extremely short cycle times are possible thanks to parallel plasticizing function.



## *High-performance hydraulic system*

### *Extra high injection speeds*

- The injection units are equipped with hydraulic accumulators to reach the high injection speeds and acceleration rates required for thin-walled parts.
- Pressure loss is minimized thanks to the short distance between the hydraulic accumulators and the hydraulic block.
- The fast-reacting servo valves installed on the integrated hydraulic block ensure excellent precision and repeatability.

### *Parallel operation*

- Loading of the accumulators via a separate loading pump with a reinforced drive.
- Separate operation of the clamping unit with a hydraulic pump of its own, independent of the accumulators.
- Capacity for parallel operation of all functions (opening, closing, ejection, core pulls, plasticizing) is available in this series as standard.



# The UNILOG B6<sup>s</sup> control system generation

UNILOG B6 is the name of the new control system generation that is setting benchmarks in user-friendliness, speed and precision. It is used across the entire product portfolio. A powerful system concept optimally geared to the requirements of hydraulics / sensor technology ensures fast, accurate movements along all axes of the machine. Precise analysis of all important process parameters provides the user with the control required for demanding applications.

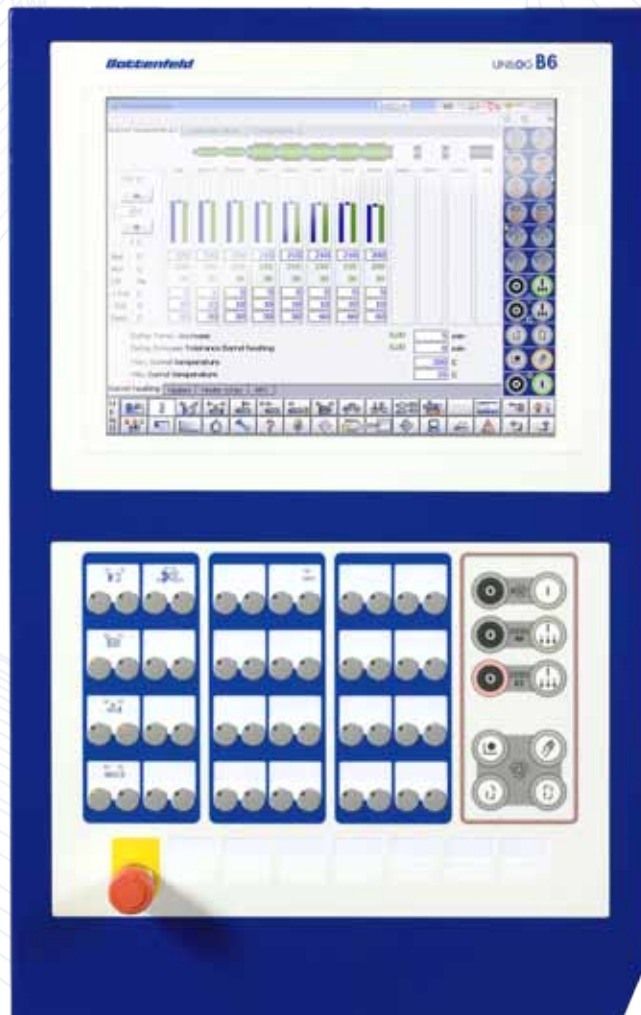

- 15" TFT color screen with unlimited touch screen functionality for operation and display.
- 2 rows of soft keys to select machine functions.
- Manual operating panel with 48 membrane keys to operate the machine's axes and optional equipment.
- Space for 7 additional optional mechanical switches/keys.
- 10 membrane keys with luminous rings are available for the basic machine functions (drive, operation modes, heaters).
- The complete machine documentation including all operation manuals, spare parts drawings and parts lists can also be retrieved. In addition, users can integrate their own PDF files and make them available to machine operators.
- USB interfaces are available on the operating unit to connect peripheral equipment such as a printer, keyboard or USB stick, or they may be used as an access control system in combination with the integrated password system. An Ethernet interface is installed in the control cabinet at the rear.

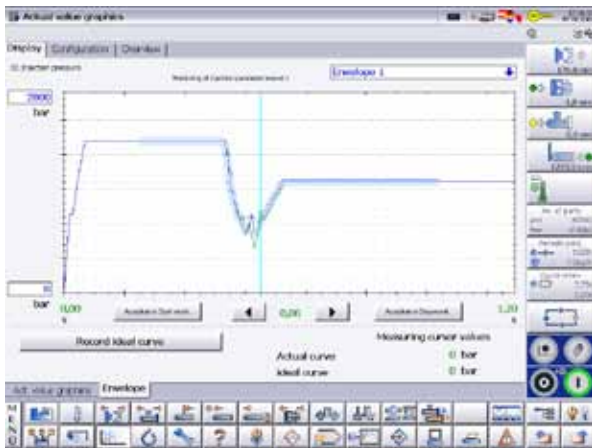

## Quality monitoring

With up to four envelope curves, the monitoring parameters are optimally adapted to the individual process.

An ideal curve serves as monitoring reference within the tolerance margin. Whenever the tolerance margin is exceeded, an alarm is triggered and the faulty part automatically sorted out.

Every parameter can be visualized via the quality table and evaluated by means of an SPC chart.

## Cycle time analysis

The purpose of cycle time analysis is to record and optimize all movements. It is a fast and simple method of defining the optimal cycle.

The ideal cycle is stored as part of the mold data set and can be retrieved for the next production run of the mold. This enables quick recognition and correction of any process deviations.

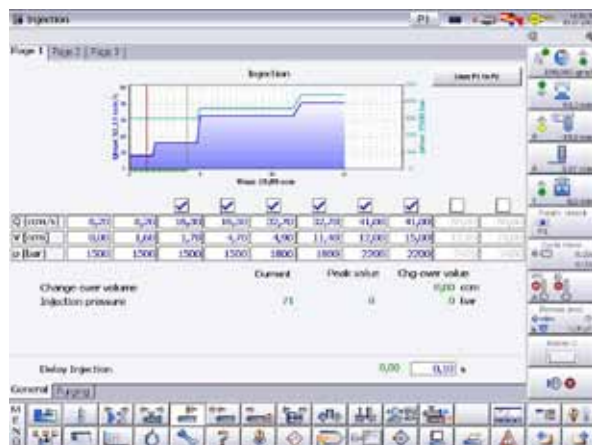

## Injection

The combination of tabular input with graphic display facilitates setting of the machine. The number of profile points is set simply by checking boxes.

A status bar on the right side of the screen gives a quick overview of the current machine status. The data is entered in physical units; alternatively, settings can be made graphically.

## Mold safety

The dual mold safety provides optimized protection due to free adjustable mold safety force. Additionally, the mold safety force and speed is monitored by an envelope curve.

An innovative algorithm enables easy usability with just one parameter. The start-up tolerance can be set up bigger for a certain number of start-up cycles.

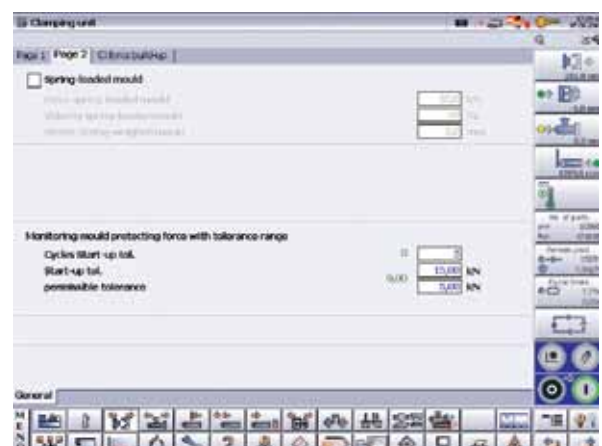

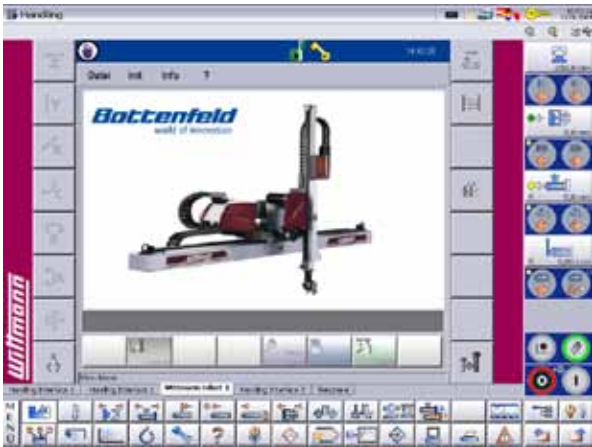

## Robot control

WITTMANN robots are operated simply and flexibly via the machine's monitor screen, no switch-over is necessary between machine and robot control.

The total overview is given on one screen. The control system of the robot itself is still placed directly on the robot.

Communication takes place via a CAN bus system, the EUROMAP interface remains free.

## Webcam

A webcam is integrated in the injection molding machine to visualize production monitoring. This makes it possible to display areas on the B6 control system that are normally not open to view, such as robot-assisted part deposition or the mold area.

The integrated webcam is used in particular also for Web-Service 24/7. Intelligible pictures of the problem situation on site can be transmitted to our global support center to enable effective analysis.

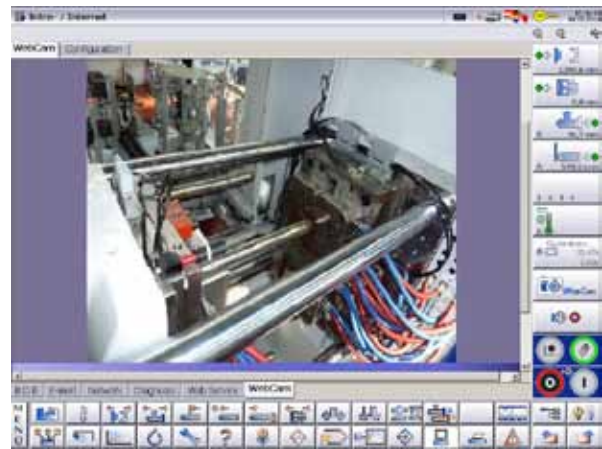

## Process data acquisition via K4

We offer BATTENFELD K4, a process data acquisition software that provides access to a central database. Centralized data administration runs on a server and is also directly integrated in the UNILog B6. Thus the plant's entire machinery can be monitored and all machine data accessed via every machine control system.

K4 provides a unique scope of functions. It not only offers machine parameter settings and quality assurance, but also maintenance records, preliminary and final costing, order-related staff work time logging and hall layout, as well as innumerable evaluation options including open item management, everything covered by and available from a single system.

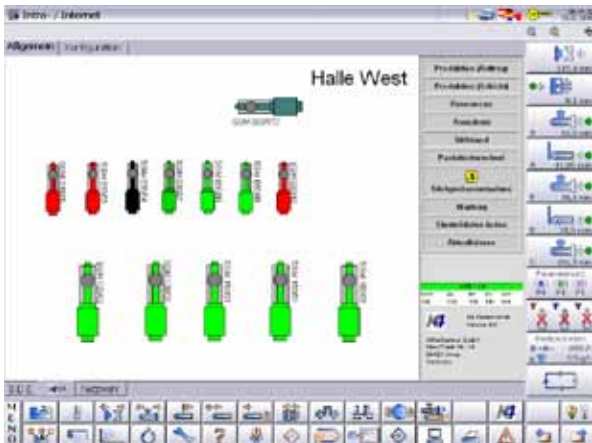

## Web-Service 24/7

WITTMANN BATTENFELD meets the plastics industry's demand for 24/7 availability with a global network of experts.

With the help of the web service center, experienced service engineers establish a direct link to the customer's injection molding machine via the Internet.

In this way, actual service tasks on the machines are performed quickly and flexibly, which ensures optimal productivity and conservation of value.



# The fast TM Xpress for cost-efficient applications

The high-speed TM Xpress series from WITTMANN BATTENFELD provides the ideal basis for a great number of applications. Whether it be thin-walled packaging parts (such as yoghurt cups, trays or IML-decorated cups), disposable medical products (syringe barrels, pistons, etc.) or high-precision industrial components, in cooperation with our team of

specialists, we will work out the optimal equipment package for every application. We put a special focus on targeted project management to ensure maximum performance for every production line.

## Turnkey in-mold labeling systems

In-mold labeling (IML) is a modern technology to produce plastics packaging. In this process, thermoplastic film is inserted directly into the mold prior to injection and then amalgamated with the molded part. With this technology, such products can be individually fitted with multi-colored inscriptions and decorations at low cost.



Packaging produced in an IML process offers highest quality standards, since the label is firmly bonded to the package. The drawbacks of conventional adhesive labels are absent. Moreover, the finished package can be manufactured in a single production step.



***For IML production, the WITTMANN group offers turnkey solutions from a single source***

- Injection molding machines from WITTMANN BATTENFELD.
- IML molds from the WITTMANN group's French subsidiary, which is an IML specialist. This company supplies high-performance molds in excellent quality, capable of extremely short cycle times, as well as development and design services for both molded parts and labels.
- Peripheral equipment from WITTMANN.



As a customer of the WITTMANN group, you will get a 100% tried-and-tested, optimized package deal – with a considerable reduction in start-up time and consequently in total investment costs.

# Application examples

## Closing systems

The TM Xpress series is ideally suited for manufacturing screw caps and closing systems for pouring liquids out of bottles. Equipped with a servo-electric screw drive and a high-performance screw, the machines are able to manufacture the products with multi-cavity and stack molds in minimal cycle times (depending on the product). In manufacturing screw caps, the short cycle time requires demolding of the parts in a soft, elastic state. Downstream cooling aggregates are used to prevent deformation.



## IML decoration

In the area of food packaging, printed labels are used today as eye-catchers, which are inserted into the open mold and then insert-molded in fully automatic production cells. Optimized line concepts allow the production of various packaging products (cups, trays, lids) within extremely short cycle times. Feeding, sorting and positioning of the labels as well as removal and stacking of the finished parts are taken care of by automation solutions from WITTMANN.



## Medical technology

Disposable medical products such as syringe barrels, syringe pistons, closing caps, etc. are produced in molds with high numbers of cavities and under ever-increasing competitive pressure.

Here, high-performance machinery and molds are the factors to ensure optimized, minimal cycle times. We cooperate closely with leading clean room equipment specialists to provide a clean room environment for our production cells.



### *High-precision parts, long flow paths*

In the area of industrial parts, wall thicknesses are continually minimized and optimized. Wall thicknesses of only a few tenths of a millimeter and long flow paths (for example in producing cable straps) demand a high injection performance as well as parallel movements of the machine to ensure low-cost manufacturing of such parts. The optimal machine configuration for every application can be selected from the extensive range of options available for the TM Xpress series.



### *Buckets*

The main factors influencing the cycle time in bucket production are wall thickness and cooling. To optimize cycle times for these products, the machine must be equipped for high injection performance and parallel movements. A major concern is also the removal of such bulky parts. Here, the specialists of the WITTMANN group will be glad to help you.



### *Drinking cups*

Manufacturing mass products such as drinking cups requires extremely short cycle times and optimized production equipment, including automation. Highly dynamic parts removal systems ensure economical production of these parts.





Clamping unit		TM Xpress 210	
Clamping force/clamping pressure	kN	2,100	
Distance between tie bars	mm x mm	570 x 570	
Mold height	mm	250 ... 600	
Opening stroke	mm	530	
Max. daylight	mm	1,130	
Ejector stroke/ejector force	mm/kN	180/41.2	
Dry cycle time <sup>1)</sup>	s - mm	1.7 - 399	
Injection unit		1350	
Screw diameter	mm	50	55
Screw stroke	mm	275	
Screw L/D ratio		22	
Theoretical shot volume	cm <sup>3</sup>	540	653
Specific injection pressure	bar	2,470	2,041
Max. screw speed	min <sup>-1</sup>	400	
Max. plasticizing rate (HDPE) <sup>2)</sup>	g/s	62	81
Max. screw torque	Nm	1,300	
Nozzle stroke/contact force	mm/kN	400/100	
Injection rate into air with hydraulic accumulator	cm <sup>3</sup> /s	1,178	1,426
Drive			
Drive power	kW	45	
Oil tank volume	l	400	
Electrical power supply without/ with Europackage	kVA	134/162	
Weight, dimensions			
Net weight (exclusive oil)	kg	10,200	
Length x width x height <sup>3)</sup>	m	5.9 x 1.6 x 2.4	
Max. mold weight <sup>4)</sup> / min. mold diameter	kg/mm	1,800/500	

<sup>1)</sup> according to EUROMAP 6    <sup>2)</sup> HDPE MFI 8 according to WITTMANN BATTENFELD norm  
<sup>3)</sup> max. length with max. screw diameter in back position and min. mold height    <sup>4)</sup> max. 2/3 on clamping platen

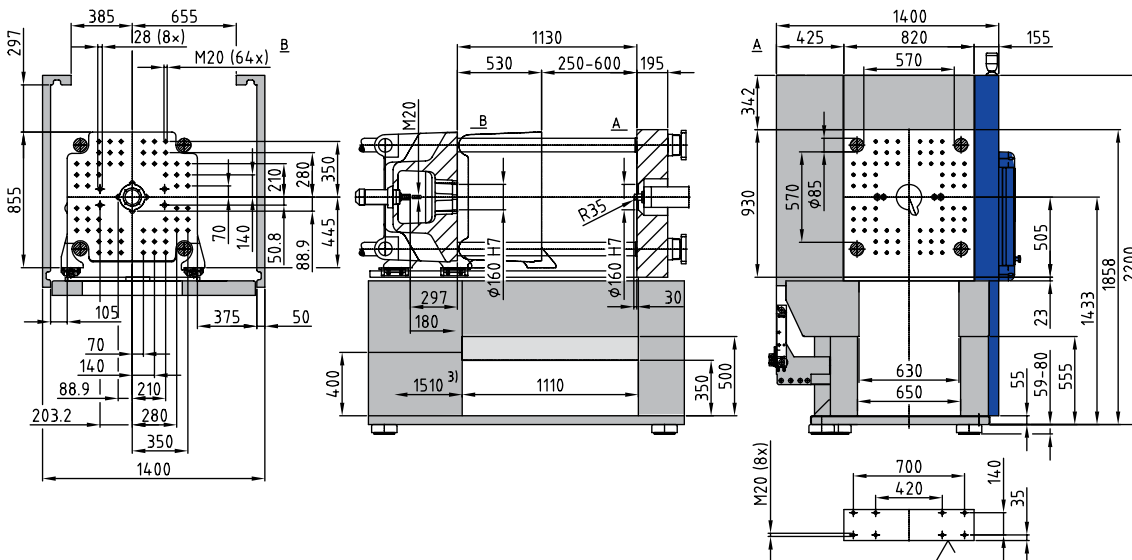

Clamping unit		TM Xpress 270			
Clamping force/clamping pressure	kN	2,700			
Distance between tie bars	mm x mm	630 x 630			
Mold height	mm	250 ... 650			
Opening stroke	mm	600			
Max. daylight	mm	1,250			
Ejector stroke/ejector force	mm/kN	200/59			
Dry cycle time <sup>1)</sup>	s - mm	1.8 - 441			
Injection unit		1350		2250	
Screw diameter	mm	50	55	55	65
Screw stroke	mm	275		325	
Screw L/D ratio		22		22	
Theoretical shot volume	cm <sup>3</sup>	540	653	772	1,078
Specific injection pressure	bar	2,470	2,041	2,500	2,070
Max. screw speed	min <sup>-1</sup>	400		350	
Max. plasticizing rate (HDPE) <sup>2)</sup>	g/s	62	81	71	110
Max. screw torque	Nm	1,300		1,800	
Nozzle stroke/contact force	mm/kN	400/100		500/129	
Injection rate into air with hydraulic accumulator	cm <sup>3</sup> /s	1,178	1,426	1,425	1,991
Drive					
Drive power	kW	55		55	
Oil tank volume	l	550		550	
Electrical power supply without/ with Europackage	kVA	146/175		189/217	
Weight, dimensions					
Net weight (exclusive oil)	kg	12,000		13,200	
Length x width x height <sup>3)</sup>	m	6.2 x 1.8 x 2.4		7.2 x 1.8 x 2.4	
Max. mold weight <sup>4)</sup> / min. mold diameter	kg/mm	2,400/550		2,400/550	

<sup>1)</sup> according to EUROMAP 6    <sup>2)</sup> HDPE MFI 8 according to WITTMANN BATTENFELD norm  
<sup>3)</sup> max. length with max. screw diameter in back position and min. mold height    <sup>4)</sup> max. 2/3 on clamping platen

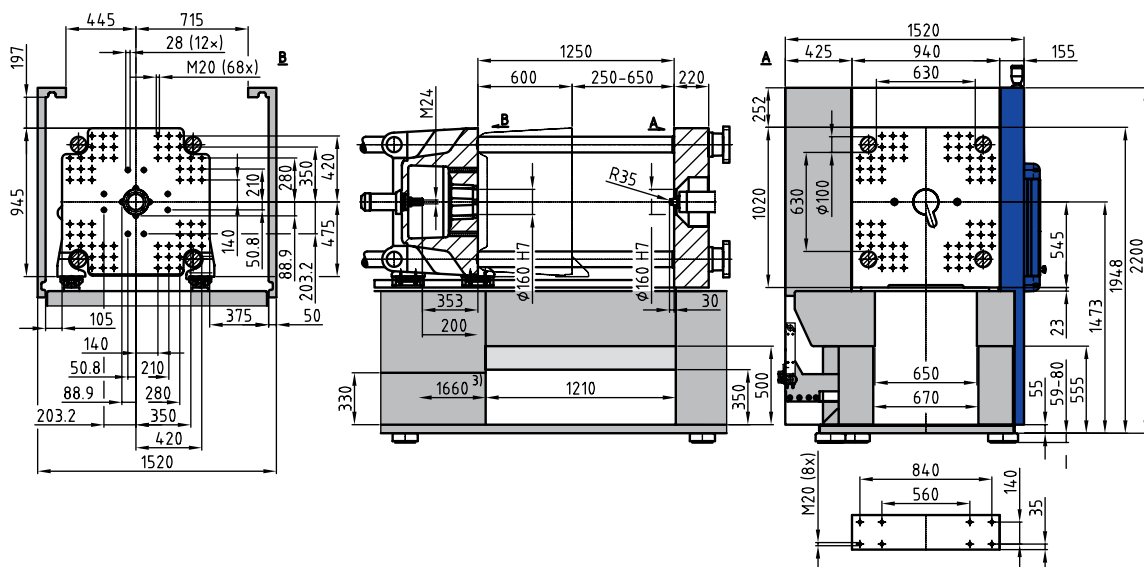

Clamping unit		TM Xpress 350			
Clamping force/clamping pressure	kN	3,500			
Distance between tie bars	mm x mm	710 x 710			
Mold height	mm	300 ... 710			
Opening stroke	mm	670			
Max. daylight	mm	1,380			
Ejector stroke/ejector force	mm/kN	200/59			
Dry cycle time <sup>1)</sup>	s - mm	1.9 - 497			
Injection unit		2250		3400	
Screw diameter	mm	55	65	65	75
Screw stroke	mm	325		375	
Screw L/D ratio		22		22	
Theoretical shot volume	cm <sup>3</sup>	772	1,078	1,244	1,657
Specific injection pressure	bar	2,500	2,070	2,500	2,022
Max. screw speed	min <sup>-1</sup>	350		300	
Max. plasticizing rate (HDPE) <sup>2)</sup>	g/s	71	110	94	137
Max. screw torque	Nm	1,800		2,800	
Nozzle stroke/contact force	mm/kN	500/129		500/129	
Injection rate into air with hydraulic accumulator	cm <sup>3</sup> /s	1,425	1,991	1,659	2,209
Drive					
Drive power	kW	75		75	
Oil tank volume	l	650		650	
Electrical power supply without/with Europackage	kVA	215/243		244/272	
Weight, dimensions					
Net weight (exclusive oil)	kg	16,800		18,000	
Length x width x height <sup>3)</sup>	m	7.5 x 1.9 x 2.6		7.7 x 1.9 x 2.6	
Max. mold weight <sup>4)</sup> /min. mold diameter	kg/mm	3,200/600		3,200/600	

<sup>1)</sup> according to EUROMAP 6    <sup>2)</sup> HDPE MFI 8 according to WITTMANN BATTENFELD norm  
<sup>3)</sup> max. length with max. screw diameter in back position and min. mold height    <sup>4)</sup> max. 2/3 on clamping platen

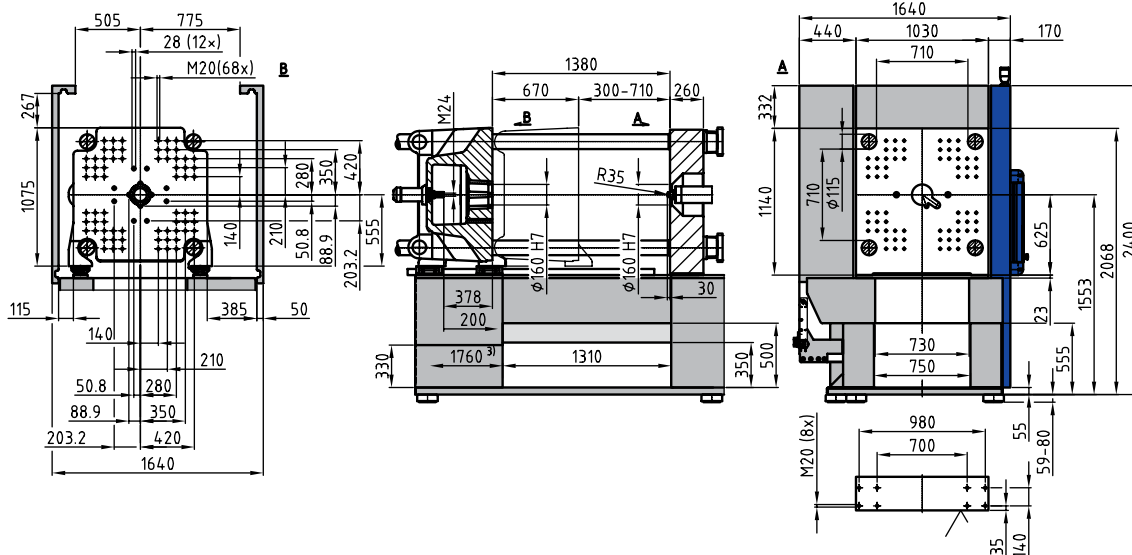

Clamping unit		TM Xpress 450			
Clamping force/clamping pressure	kN	4,500			
Distance between tie bars	mm x mm	800 x 800			
Mold height	mm	300 ... 770			
Opening stroke	mm	760			
Max. daylight	mm	1,530			
Ejector stroke/ejector force	mm/kN	250/81			
Dry cycle time <sup>1)</sup>	s - mm	2.4 - 560			
Injection unit		2250		3400	
Screw diameter	mm	55	65	65	75
Screw stroke	mm	325		375	
Screw L/D ratio		22		22	
Theoretical shot volume	cm <sup>3</sup>	772	1,078	1,244	1,657
Specific injection pressure	bar	2,500	2,070	2,500	2,022
Max. screw speed	min <sup>-1</sup>	350		300	
Max. plasticizing rate (HDPE) <sup>2)</sup>	g/s	71	110	94	137
Max. screw torque	Nm	1,800		2,800	
Nozzle stroke/contact force	mm/kN	500/129		500/129	
Injection rate into air with hydraulic accumulator	cm <sup>3</sup> /s	1,425	1,991	1,659	2,209
Drive					
Drive power	kW	90		90	
Oil tank volume	l	800		800	
Electrical power supply without/ with Europackage	kVA	230/258		259/287	
Weight, dimensions					
Net weight (exclusive oil)	kg	20,700		21,900	
Length x width x height <sup>3)</sup>	m	8 x 2.1 x 2.6		8.1 x 2.1 x 2.6	
Max. mold weight <sup>4)</sup> / min. mold diameter	kg/mm	4,000/700		4,000/700	

<sup>1)</sup> according to EUROMAP 6    <sup>2)</sup> HDPE MFI 8 according to WITTMANN BATTENFELD norm  
<sup>3)</sup> max. length with max. screw diameter in back position and min. mold height    <sup>4)</sup> max. 2/3 on clamping platen

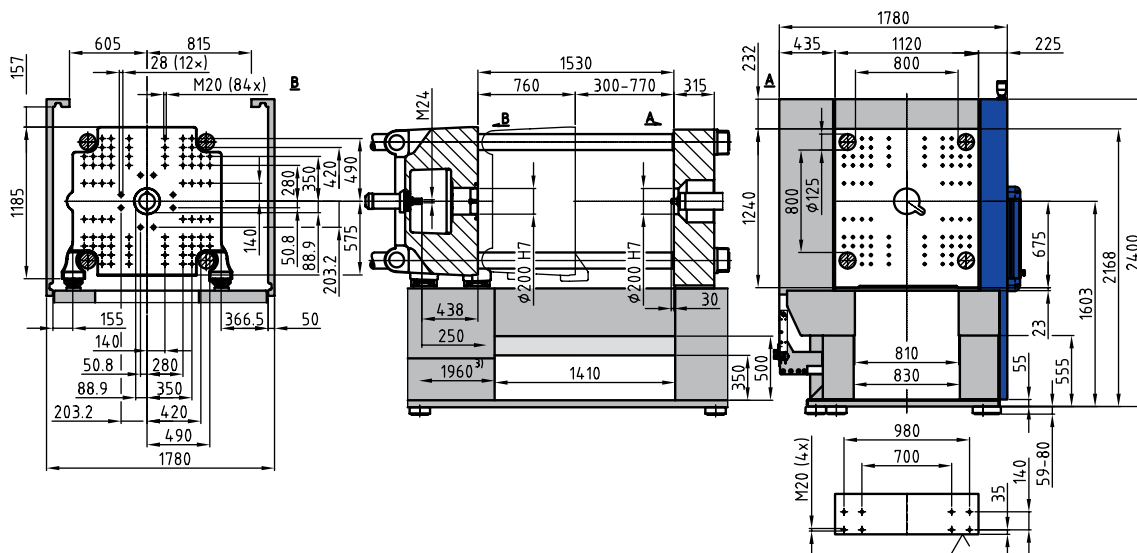

# Standard Features TM Xpress UNILOG B6<sup>S</sup>

## Hydraulic

Hydraulic unit with variable pressure and speed axial piston pump
Hydraulic accumulator for fast injection incl. loading pump and parallel ejector movement and core pull movement via double pump
Reinforced drive motor
Extra large oil cooler
Injection parallel to clamp force build-up
Oil filtration by fine flow filter with electrical clogging indicator
Oil level indicator with alarm
Closed-loop oil temperature control with oil pre-heating
Oil temperature monitoring
Oil tank with connections for external oil filtration
Separate hand keys for core pulls
Hydraulic pressure displayed

## Clamping unit

Clamping force adjustable via touch-screen incl. clamping force control
Closing and opening speed adjustable
Closing and opening force adjustable
Mold safety program via envelope curves monitoring
Moving platen supported by positioned linear guides
Platen drillings and register rings according to EUROMAP
Fixing holes for robot on top of the fixed platen according to EUROMAP/VDMA
Hydraulic mold close inhibit, electrically monitored on operator side
Central hydraulic multi-stroke ejector, adjustable
Flexible parts removal from 3 directions

## Injection unit

Servo closed loop control
Barrier mixing screw, screw L/D = 22 with check valve, wear resistant screw and barrel AK+
Screw drive by a. c. servo motor
Thermocouple failure monitor
Maximum temperature supervision
Plug-in ceramic heater bands
Temperature control of feed throat integrated
Open nozzle
Relief valve for nozzle pressure control
Purge guard electrically monitored
Selectable barrel stand-by temperature
Physical units – bar, ccm, mm/s etc.
Screw protection
Material shut off mechanism
Linear bearings for the injection unit

## Safety gate

Monitored safety gate, CE-confirmed
Maintenance-free safety gate locked by electromagnet
Safety gate free for mold change and handling by robot

## Electrical components

Operating voltage 230/400 V-3PH, 50 Hz
Control cabinet cooler
Software for operating hours counter/shot counter
Closing/opening – 5 profile steps
Ejection forward/back – 3 profile steps
Nozzle forward/back – 3 profile steps
Injection/holding pressure – 10 profile steps
Screw speed/back pressure – 6 profile steps
Parts counter with good/bad part evaluation
Purging program
Stroke zero offset settings
Start-up program
Adjustable injection pressure limitation
Switchover to holding pressure MASTER/SLAVE by injection time, screw stroke/injection volume and injection pressure
Self-teaching temperature controller
Display of temperature inside electrical cabinet
Seven-day timer
Access authorization via USB interface
Access protection via password system
Freely configurable status bar
Physical, process-related units
15" TFT color screen – touchscreen
Manual board with foil buttons
Automatic dimming
Logbook with filter function
User programming system "APS"
Cycle time analysis
4 freely configurable network connections
Freely configurable screen pages "user page"
Notepad function
Hardcopy function
Internal data storage via USB connection or network
Online language selection
Online selection of imperial or metric units
Operator manual incl. hydr., mech. and el. schedules online
Time monitoring
Quality table, 10,000 storage depth
Trend diagram
SPC charts
Events protocol (logbook) for 10,000 events
Actual value graphics with 16 curves
4 envelope curves monitorings
Injection Integral supervision
Metering Integral supervision
Alarm message via email
USB – 2 x operating unit
1 Ethernet interface
Printer via USB connection or network

## Accessories

Levelling pads
Paint RAL 9002 grey white/RAL 5002 ultramarine blue

# Optional Features TM Xpress UNILOG B6<sup>S</sup>

Hydraulic
Hydraulic core pulls – limit switch function according to EUROMAP 13 – pressure and speeds adjustable
Pneumatic core pull
Pneumatic manifold for moldmaster nozzle (controlled 1 nozzle or more parallel in the mold)
Hydraulic manifold for moldmaster nozzle (controlling 1 nozzle or more parallel in the mold)
Filter in water inlet of oil cooler
Adapter with ball valve on the oil tank for oil maintenance
Separate bypass filtration unit

Clamping unit
Increased stationary platen thickness
Non-standard mold height after customers request
SPI bolt pattern
Ejector cross in clamping platen as per EUROMAP/SPI
Maximum ejector force increased
Mechanical ejector couple
Ejector platen safety device
Mechanical mold safety mechanism
Air valve, action initiated and timer

Injection unit
Needle type shut-off nozzle, pneumatic operated
Screw and barrel L/D = 26
Barrel insulation

Safety gate
Operating safety gate at the rear side
Safety gate clearance operator side/rear side extended
Safety gate rear side lowered at the top of the upper tiebar

Cooling and conditioning
Additional flow controller with temperature gauges
Shut-off valve for cooling water battery
Blow out valve for cooling water battery
Hosting of cooling circuits on the fixed platen of the moving platen

Electrical components
Temperature control zone for hot runner
Non-contact stroke transducers (standard from 350 t)
Special voltage
Additional socket
Fuse protection for sockets
Interface for handling equipment
Energy consumption analysis
Switch over to holding pressure by cavity or melt pressure
Switch over to holding pressure by external signal
Purging program through the open mold
Melt cushion control
Audible alarm
Analog temperature control interface
Temperature control interface digital, serial 20mA TTY protocol
CAN-Bus interface for mold conditioner as per EUROMAP 66-2
Interface for robots as per EUROMAP 67
Adaptor from EUROMAP 67 to EUROMAP 12
Interface for conveyor belt
Host computer interface/PDA (EUROMAP 63)
Relays contact parallel to plasticizing
Machine fault (potential-free contact)
BNC connectors for injection process analysis
Interface for common data storage with robot
Second injection data setting for automatic start-up
Web- and remote service
Control button BATTENFELD K4 incl. interface EUROMAP 63 – K4

Accessoires
Special paint and/or touch-up paint
Tool kit
USB stick for data storage
Webcam

## Possible combinations of clamping units/injection units

Clamping unit	Injection unit			
	t	1350	2250	3400
160	•			
210	•			
270	•	•		
350		•		•
450		•		•

# Technology working for you.

## **Wittmann Battenfeld GmbH**

Wiener Neustädter Strasse 81  
2542 Kottlingbrunn | Austria  
Tel.: +43 2252 404-0 | Fax: +43 2252 404-1062  
info@wittmann-group.com

[www.wittmann-group.com](http://www.wittmann-group.com)

## **Wittmann Battenfeld GmbH & Co. KG**

Werner-Battenfeld-Strasse 1  
58540 Meinerzhagen | Germany  
Tel.: +49 2354 72-0 | Fax: +49 2354 72-485  
info@wittmann-group.com

[www.wittmann-group.com](http://www.wittmann-group.com)